



Experience Innovation

## Model: 6" Compressor-Assisted Solids Handling Pump

Name: 6JSCE

With its heavy-duty cast-iron construction and fast priming capabilities, the Thompson 6JSCE solids handling end suction centrifugal pump leads the industry in construction, industrial and municipal applications. The Thompson 6JSCE is designed for moderate flows up to 2,680 gpm and heads up to 190 feet making it perfect for sewage bypass pumping or general construction dewatering.



Photo shown may not be exact model.

Consult factory for other options.

Pump End Materials	
<b>Pump Casing</b>	Heavy-duty class 30 ductile iron.
<b>Impeller</b>	Dynamically balanced, non-clogging, enclosed, 65-45-12 ductile iron with rear-equalizing vanes to reduce axial loading and prolong seal and bearing life; diameter 12".
<b>Mechanical Seal</b>	Dry-running, grease or oil lubricated with tungsten carbide rotating and silicon carbide stationary seal faces. Single inside mounted, non-pusher type with self-adjusting elastomeric bellows. Other components are 304 stainless steel and Viton.
<b>Head</b>	Rugged, back pull out design, heavy-duty class 30 cast iron with tapered bore design.
<b>Bearings</b>	Heavy-duty grease lubricated to carry both axial and radial loads.
<b>Bearing Frame</b>	Heavy-duty class 30 ductile iron.
<b>Shaft</b>	SAE 1144 steel fitted with a 416 stainless steel shaft sleeve.

Technical Specifications			
Suction Size	6 in (15.24 cm)	Approximate Dry Weight	3,150 lbs (1,428.81 kg)
Discharge Size	6 in (15.24 cm)	Best Efficiency	80%
Maximum Solids Handling	3 in (7.62 cm)	Maximum Operating Speed	2,000 rpm
Maximum Operating Temperature	200° F (93.33° C)	Maximum Operating Pressure	82.3 psi (567.10 kPa)

Fuel Tank Options*	Deutz	Cummins
Modular (M)	114 Gal	39 Hours
Double-Wall (D)	105 Gal	35 Hours
Modular Large Capacity (X)	200 Gal	68 Hours
Double-Wall Large Capacity (Z)	150 Gal	51 Hours

\*Contact factory for fuel tank sizes not listed above.

**Thompson Pump and Manufacturing Co., Inc.**  
4620 City Center Drive, Port Orange, FL 32129 USA  
www.thompsonpump.com

Nationwide 800-767-7310 • International +1-386-767-7310  
sales@thompsonpump.com

Jun-20

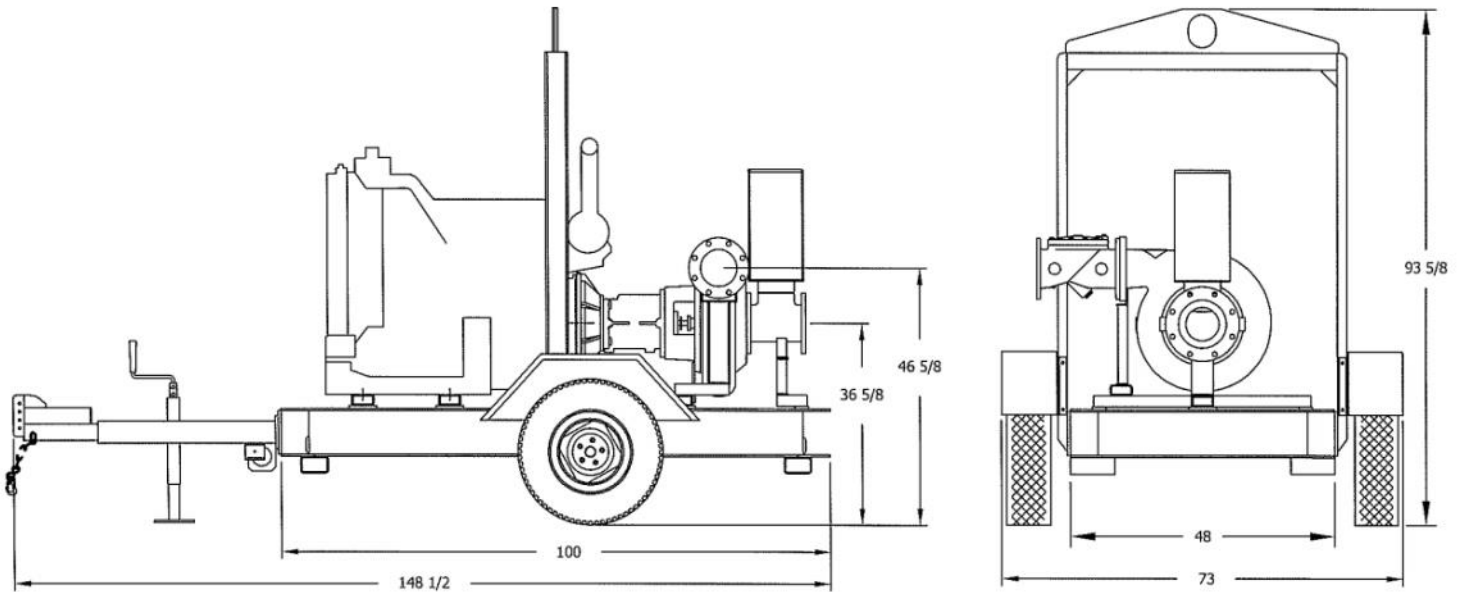
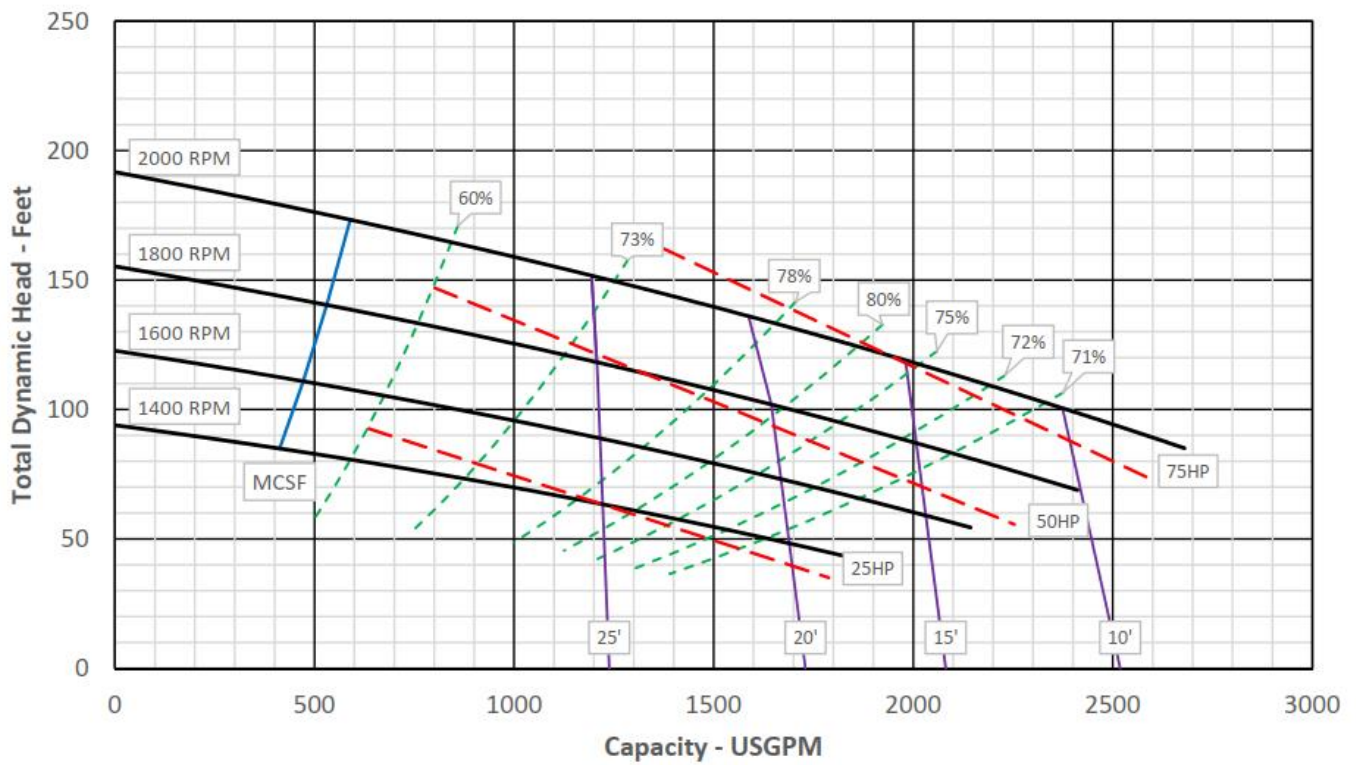

Deutz TD3.6L4— 74 hp @ 2,400 rpm					
Typical Operating Speed	2,000 rpm	Engine Speed		Run Time*	
Maximum Head	190 ft (57.91 m)	2,000 rpm	0.371 lb/hp-hr	25 hrs	
Maximum Flow Capacity	2,680 gpm (608.36 m <sup>3</sup> /hr)	1,800 rpm	0.366 lb/hp-hr	34 hrs	
Maximum Fuel Consumption	4.5 gph (17.03 L/hr)	1,600 rpm	0.359 lb-hp-hr	40 hrs	

Cummins QSB2.8—74 hp @ 2,400 rpm					
Typical Operating Speed	2,000 rpm	Engine Speed		Run Time*	
Maximum Head	190 ft (57.91 m)	2,000 rpm	0.387 lb/hp-hr	24 hrs	
Maximum Flow Capacity	2,680 gpm (608.36 m <sup>3</sup> /hr)	1,800 rpm	0.378 lb/hp-hr	33 hrs	
Maximum Fuel Consumption	4.69 gph (17.75 L/hr)	1,600 rpm	0.372 lb-hp-hr	39 hrs	

\*Engine run times calculated based on a 114 gallon fuel tank.

Specifications and illustrations are subject to revision without notice and without incurring any obligation for previous or subsequent equipment sold. Thompson Pump (ISO 9001:2015) makes no representation regarding the completeness or accuracy of this information and is not liable for any direct or indirect damages arising from or relating to this information or its use. Capacity & Head are shown for comparative purposes. Consult Thompson factory for exact capabilities.