



Model: 6" Compressor-Assisted Solids Handling Pump

Name: 6JSCD

Experience Innovation

With its heavy-duty cast-iron construction and fast priming capabilities, the Thompson 6JSCD solids handling end suction centrifugal pump leads the industry in construction, industrial and municipal applications. The Thompson 6JSCD is designed for moderate flows up to 1,460 gpm and heads up to 340 feet making it perfect for sewage bypass pumping or general construction dewatering.



Photo shown may not be exact model.
Consult factory for other options.

| Pump End Materials | |
|------------------------|---|
| Pump Casing | Heavy-duty class 30 ductile iron. |
| Impeller | Dynamically balanced, non-clogging, enclosed, 65-45-12 ductile iron with rear-equalizing vanes to reduce axial loading and prolong seal and bearing life; diameter 14". |
| Mechanical Seal | Dry-running, grease or oil lubricated with tungsten carbide rotating and silicon carbide stationary seal faces. Single inside mounted, non-pusher type with self-adjusting elastomeric bellows. Other components are 304 stainless steel and Viton. |
| Head | Rugged, back pull out design, heavy-duty class 30 cast iron with tapered bore design. |
| Bearings | Heavy-duty grease lubricated to carry both axial and radial loads. |
| Bearing Frame | Heavy-duty class 30 ductile iron. |
| Shaft | SAE 1144 fitted with a 416 stainless steel shaft |

| Technical Specifications | | | |
|-------------------------------|-------------------|----------------------------|-------------------------|
| Suction Size | 6 in (15.24 cm) | Approximate Dry Weight | 5,270 lbs (2,390.43 kg) |
| Discharge Size | 6 in (15.24 cm) | Best Efficiency | 71% |
| Maximum Solids Handling | 3 in (7.62 cm) | Maximum Operating Speed | 2,300 rpm |
| Maximum Operating Temperature | 200° F (93.33° C) | Maximum Operating Pressure | 147 psi (1,014.8 kPa) |

| Fuel Tank Options* | Cummins | JD HC06 | JD HC04 |
|--------------------------------|---------------------|----------|----------|
| Modular (M) | 127 Gal 29 Hours | 29 Hours | 28 Hours |
| Double-Wall (D) | 94 Gal 21 Hours | 21 Hours | 21 Hours |
| Modular Large Capacity (X) | 200 Gal 45 Hours | 46 Hours | 45 Hours |
| Double-Wall Large Capacity (Z) | 145 Gal 33 Hours | 33 Hours | 32 Hours |

*Contact factory for fuel tank sizes not listed above.

Thompson Pump and Manufacturing Co., Inc.
4620 City Center Drive, Port Orange, FL 32129 USA
www.thompsonpump.com

Nationwide 800-767-7310 • International +1-386-767-7310
sales@thompsonpump.com

Jul-20

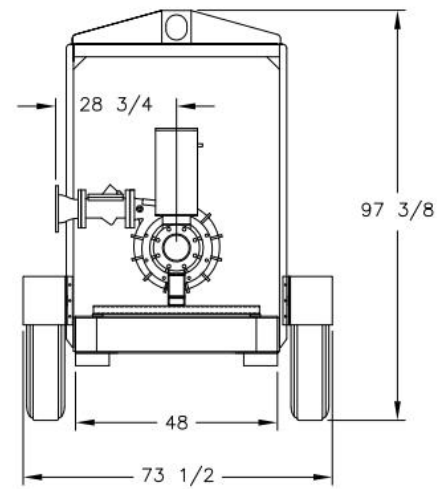
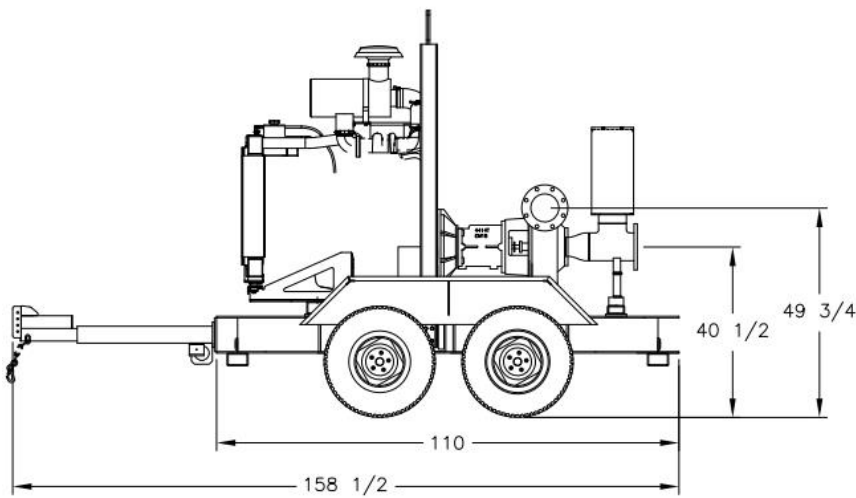
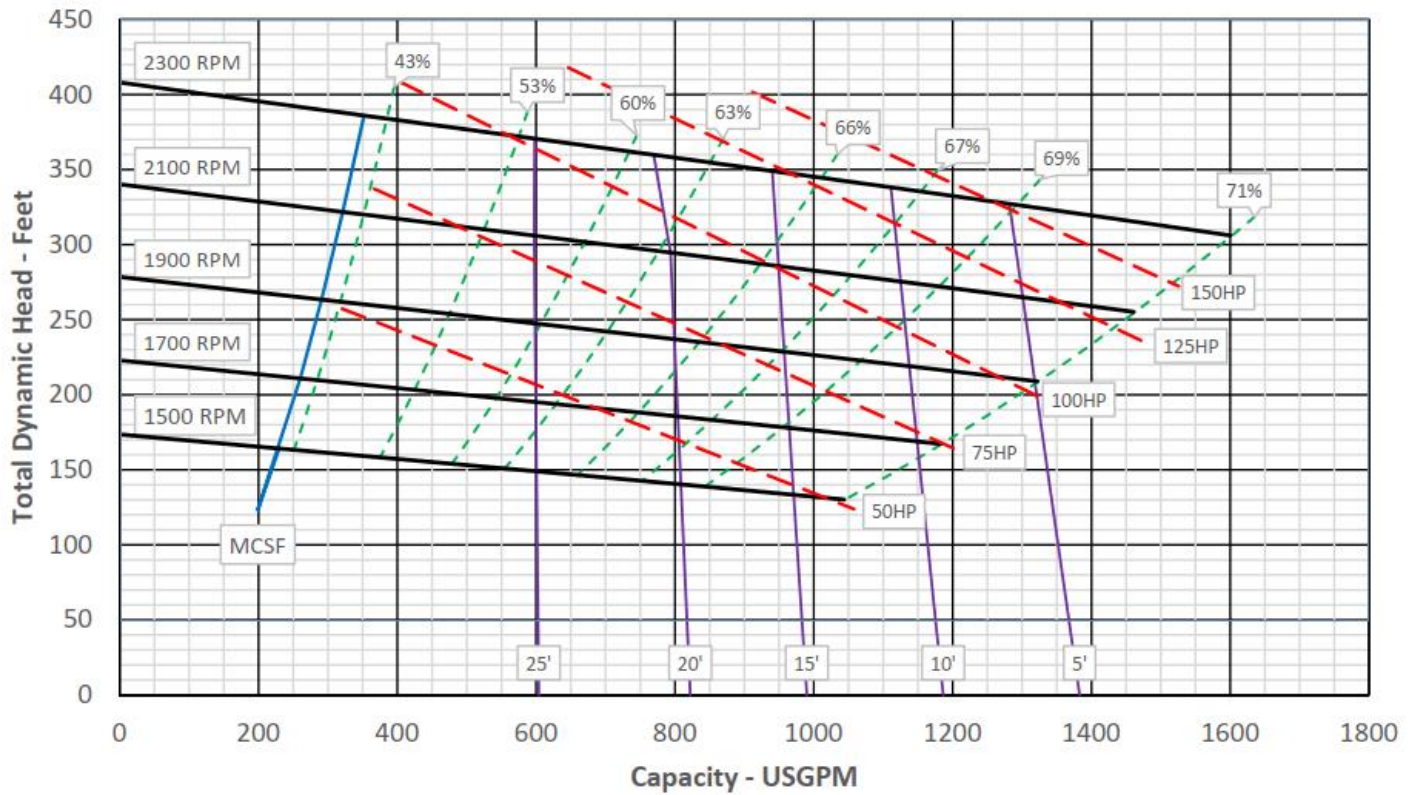

| Cummins QSB4.5 — 140 hp @ 2,200 rpm | | | | |
|-------------------------------------|--------------------------------------|--------------|----------------|-----------|
| Typical Operating Speed | 2,100 rpm | Engine Speed | Fuel Economy | Run Time* |
| Maximum Head | 340 ft (83.21 m) | 2,100 rpm | 0.348 lb/hp-hr | 18 hrs |
| Maximum Flow Capacity | 1,460 gpm (331.4 m ³ /hr) | 1,900 rpm | 0.342 lb/hp-hr | 22 hrs |
| Maximum Fuel Consumption | 6.95 gph (26.31 L/hr) | 1,700 rpm | 0.339 lb-hp-hr | 29 hrs |

| John Deere 45HC06— 139 hp @ 2,200 rpm | | | | |
|---------------------------------------|--------------------------------------|--------------|----------------|-----------|
| Typical Operating Speed | 2,100 rpm | Engine Speed | Fuel Economy | Run Time* |
| Maximum Head | 340 ft (66.45 m) | 2,100 rpm | 0.354 lb/hp-hr | 17 hrs |
| Maximum Flow Capacity | 1,460 gpm (331.4 m ³ /hr) | 1,900 rpm | 0.344 lb/hp-hr | 22 hrs |
| Maximum Fuel Consumption | 7.07 gph (26.76 L/hr) | 1,700 rpm | 0.336 lb-hp-hr | 29 hrs |

| John Deere 45HC04 — 139 hp @ 2,200 rpm | | | | |
|--|--------------------------------------|--------------|----------------|-----------|
| Typical Operating Speed | 2,100 rpm | Engine Speed | Fuel Economy | Run Time* |
| Maximum Head | 340 ft (83.21 m) | 2,100 rpm | 0.362 lb/hp-hr | 17 hrs |
| Maximum Flow Capacity | 1,460 gpm (331.4 m ³ /hr) | 1,900 rpm | 0.352 lb/hp-hr | 22 hrs |
| Maximum Fuel Consumption | 7.23 gph (27.37 L/hr) | 1,700 rpm | 0.345 lb-hp-hr | 28 hrs |

*Engine run times calculated based on a 127 gallon fuel tank.

Specifications and illustrations are subject to revision without notice and without incurring any obligation for previous or subsequent equipment sold. Thompson Pump (ISO 9001:2015) makes no representation regarding the completeness or accuracy of this information and is not liable for any direct or indirect damages arising from or relating to this information or its use. Capacity & Head are shown for comparative purposes. Consult Thompson factory for exact capabilities.